

Installation Instruction Sheet

L131 SERIES

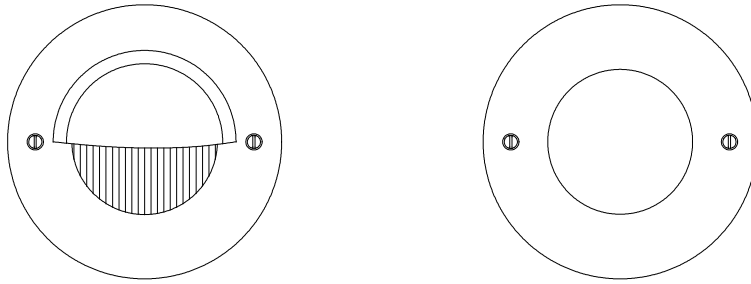

STEP 1

Remove wired channel. Bring supply wire through desired entrance of housing. Install spun steel housing (suitable for concrete pour) into wall ensuring that front housing aligns with finished wall surface. Alignment of the two ensures proper weather seal.

For Drywall mounting provide a minimum 3-1/16 inch round opening or match O.D. of housing for wall surface alignment. Mount housing to framing or provide additional structure for a secure installation. Ensure that there are no gaps between housing and wall opening for proper trim coverage.

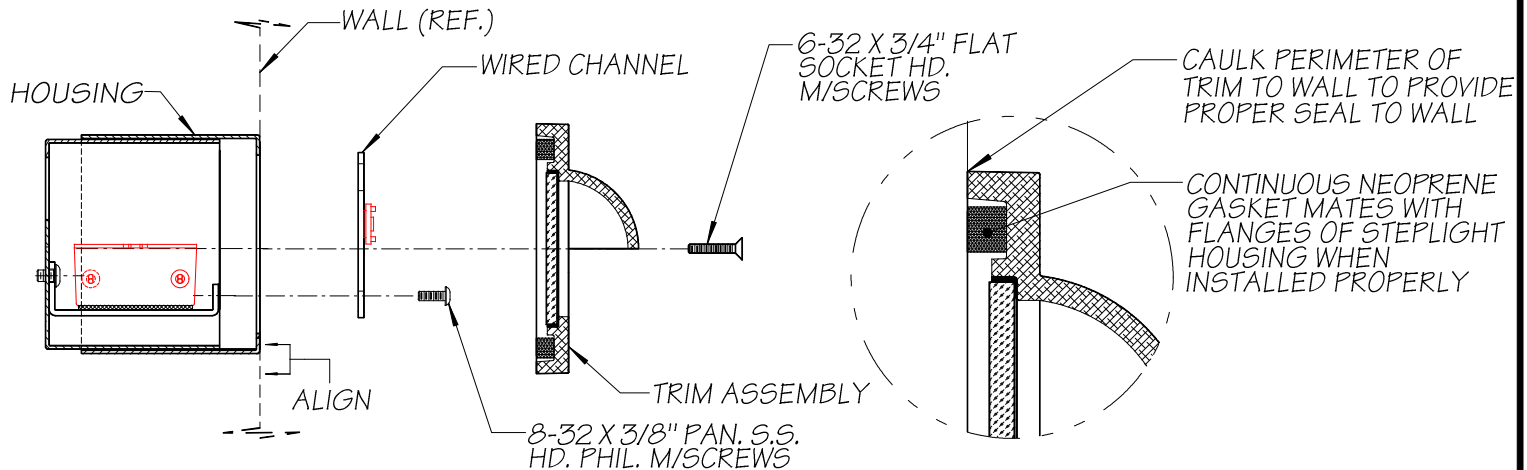

STEP 2

Ensure that power to unit is off. Remove wired channel for housing. Splice supply wires with lead wires of wired channel. Replace wired channel and fasten in place. Mount finished trim to housing using factory supplied (2) 6-32 X 3/4" stainless steel flat socket head machine screws ensuring gasket is in place for proper seal.

NOTE:

- * THIS PRODUCT MUST BE INSTALLED IN ACCORDANCE WITH THE APPLICABLE INSTALLATION CODE BY A PERSON FAMILIAR WITH THE CONSTRUCTION AND OPERATION OF THE PRODUCT AND THE HAZARDS INVOLVED.
- * CONTACT WITH ACID-WASH OF ANY TYPE TO ANY SURFACE OF STEPLIGHT WILL/MAY VOID WARRANTY.
- * RECESSED HOUSING NOT SEALED FROM MOISTURE THROUGH WALL. IF NECESSARY, PROTECTION MUST BE PROVIDED TO PREVENT WATER FROM ENTERING HOUSING INSIDE OF WALL.

