

# Installation Instruction Sheet

Catalog No.: DL180 SERIES

## STEP I:

1. DETACH TRIM ASS'Y. & SPUN REFLECTOR.
2. INSTALL PLASTER FRAME ASS'Y. USING (2) 1/2" x 20" MOUNTING BARS, PROVIDED.
3. ADJUST PLASTER FRAME SO THAT THE LOWEST POINT IS FLUSH WITH THE CEILING.
4. REMOVE J-BOX COVER.
5. PUNCH OUT DESIRED K.O. IN JUNCTION BOX AND FEED ELECTRICAL WIRES
6. MAKE APPROPRIATE ELECTRICAL WIRE CONNECTIONS.
7. REPLACE J-BOX COVER.

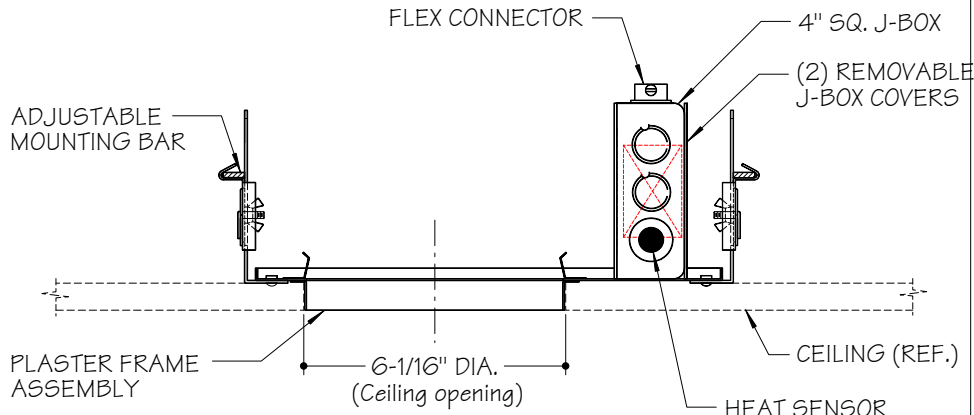

## STEP II:

1. RE-ATTACH SPUN REFLECTOR, USING SUPPLIED (2) 8-32 PAN PHILLIP HD. M/ SCREWS.
2. ROTATE SPUN REFLECTOR TO DESIRED POSITION.
3. SNAP SPUN REFLECTOR INTO PLASTER FRAME'S OPENING.

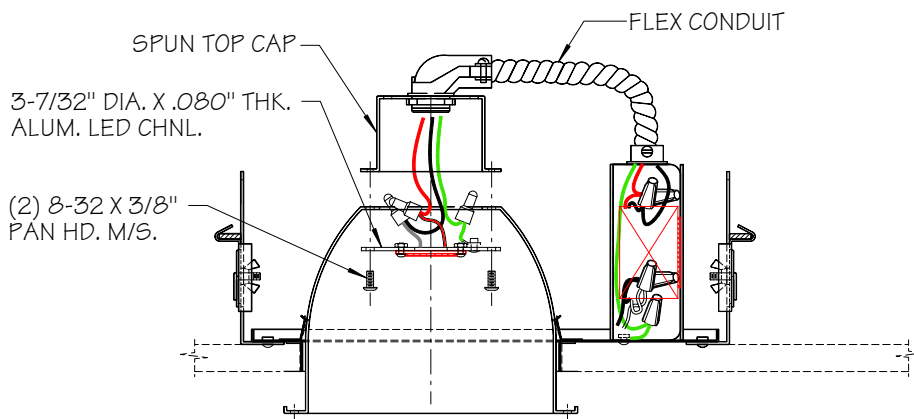

## STEP III:

1. RE-ATTACH TRIM ASSEMBLY, USING SUPPLIED (4) 8-32 SOCKET CAP HD. M/ SCREWS.

### NOTE:

CONTACT MANUFACTURER FOR L.E.D. COMPONENTS REPLACEMENT

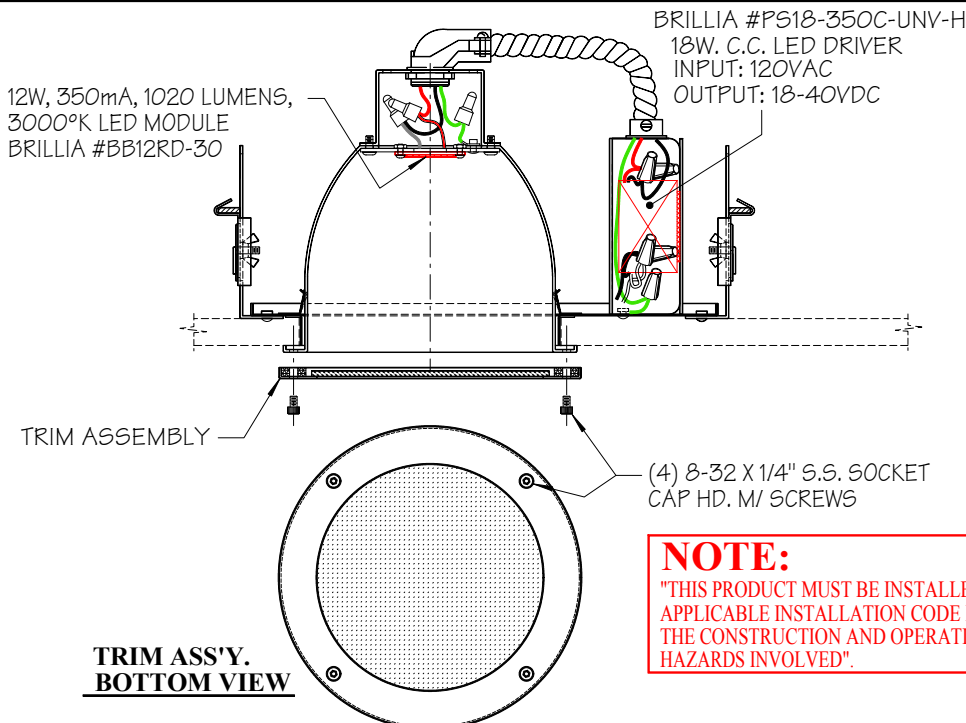

### NOTE:

"THIS PRODUCT MUST BE INSTALLED IN ACCORDANCE WITH THE APPLICABLE INSTALLATION CODE BY A PERSON FAMILIAR WITH THE CONSTRUCTION AND OPERATION OF THE PRODUCT AND THE HAZARDS INVOLVED".

TRIM ASS'Y.  
BOTTOM VIEW