

# Installation Instruction Sheet

021821R

## 2156 SERIES - RECESSED MOUNT

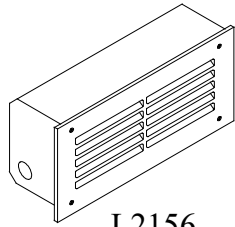

L2156  
T2156

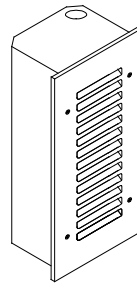

L2156V  
T2156V

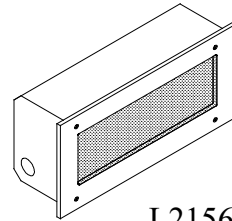

L2156G  
T2156G

### STEP 1

Remove wired channel. Bring supply wire through liquid tight connector (by others) into desired entrance. Using mounting holes on housing flanges, install 16 ga. steel housing (suitable for concrete pour) into wall ensuring that front of housing aligns with finished wall surface. Alignment of the two ensures proper weather seal. *(Caulk perimeter of housing to ensure proper seal to wall in wet and damp locations.)*

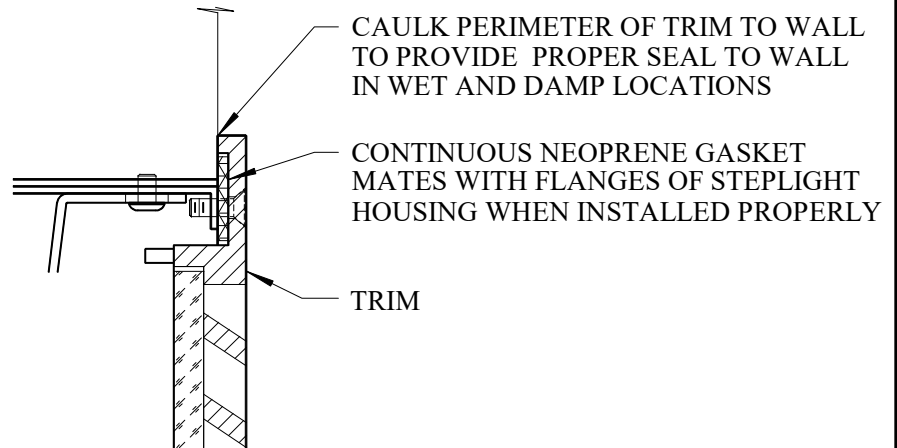
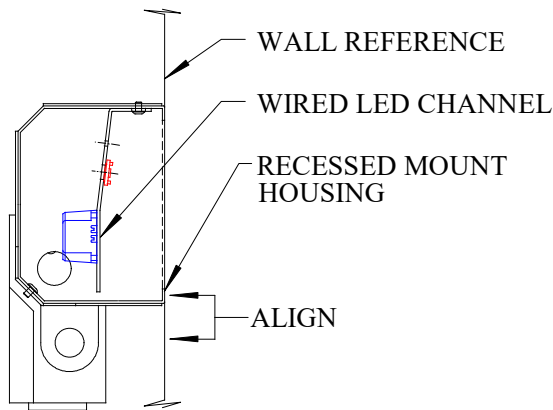

### STEP 2

Ensure that power to unit is off. Splice supply wires to lead wires from wired channel. Replace wired channel and fasten in place. Mount finished trim to housing using (4) 8-32 screws provided, ensuring gasket is in place for proper seal.

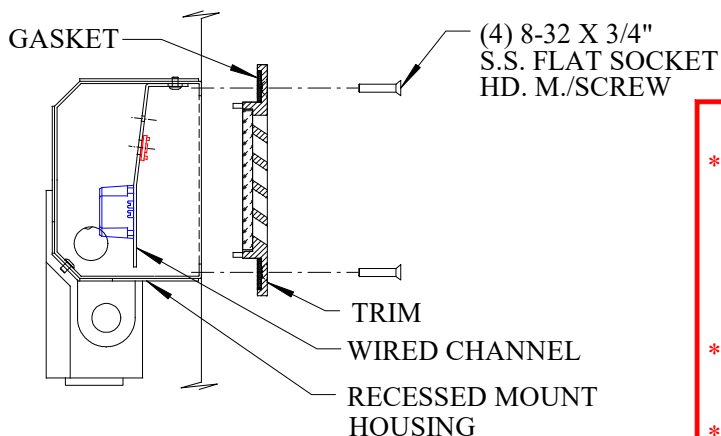

#### NOTE:

- \* THIS PRODUCT MUST BE INSTALLED IN ACCORDANCE WITH THE APPLICABLE INSTALLATION CODE BY A PERSON FAMILIAR WITH THE CONSTRUCTION AND OPERATION OF THE PRODUCT AND THE HAZARDS INVOLVED.
- \* CONTACT WITH ACID-WASH OF ANY TYPE TO ANY SURFACE OF STEPLIGHT WILL/MAY VOID WARRANTY.
- \* RECESSED HOUSING NOT SEALED FROM MOISTURE THROUGH WALL. IF NECESSARY, PROTECTION MUST BE PROVIDED TO PREVENT WATER FROM ENTERING HOUSING INSIDE OF WALL.